

VOTRONIC

Installation and Operating Manual

Solar Data Extender 3n1

No. 1440

The Votronic Solar Data Extender aggregates the data of several solar controllers for representation on a single display. Also a LCD-Charge Control S of a VBCS Triple will be supported.



Please read the mounting instructions and the operating manual including the safety regulations completely prior to starting connection and start-up.

The Solar Data Extender is compatible with the following devices:

- VOTRONIC Solar Charging Controller in SR and MPP Technology (from serial No. 14Vxx.xxxxx)
- VOTRONIC Battery Charger Type VBCS Triple
- VOTRONIC LCD Solar Computer S (from serial No. 15V40.xxxxx)
- VOTRONIC LCD-Charge Control S
- VOTRONIC VPC Series with Solar Function
- VOTRONIC Bluetooth Connector S-BC

Functioning

The Solar Data Extender aggregates the data of up to three solar controllers for representation on a single display. The usual LCD displays (such as LCD Solar Computer S or LCD-Charge Control S) can be used further.

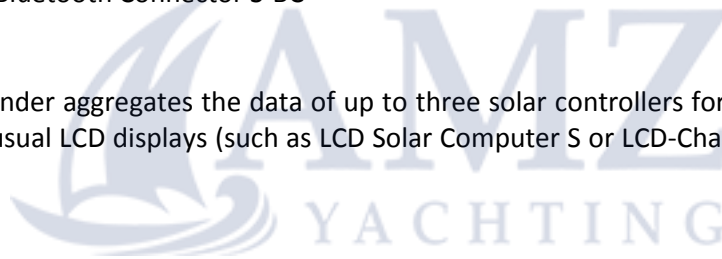

Installation and Connection:

Later installation of the Solar Data Extender is possible at any time.

It is equipped with three independent inputs (IN1, IN2, IN3). The signals are aggregated and they are made available via the output (OUT), where a solar display (such as LCD Solar Computer S) can be connected. If a VBCS Triple is connected, the input IN1 must be used.

Installation

The Solar Data Extender is connected between the Votronic Solar Charging Controller or VBCS Triple and the Display (such as LCD Solar Computer S or LCD-Charge Control S) by means of a modular cable, which is included in the standard delivery. Connection IN1 must always be connected, since it is used for voltage supply to the unit.

Below are some examples for connection:

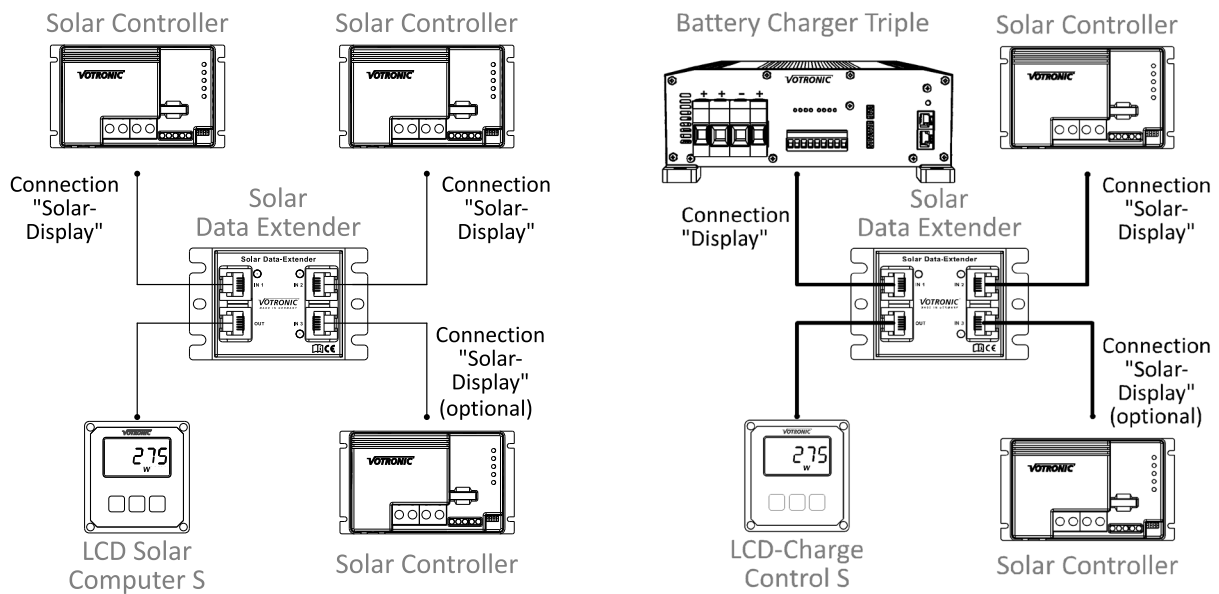

Instructions for Connection

The connections IN2 and IN3 have equal rights. They can be connected, but this is not imperative.

If more than three solar controllers exist, several Solar Data Extenders can be connected in series (cascading).

Important: For cascading IN1 must always be assigned to a solar controller.

Connection OUT can be also used to connect a VOTRONIC Bluetooth Connector S-BC (order No. 1430).

Operation

During operation, the unit recognizes automatically, if units had been connected or removed.

Intervention of the user is not possible or necessary.

LED Flashing Pattern

Simple and short flashing of the LEDs signalizes a connected solar controller or VBCS Triple in stand-by mode.

Permanent flashing of the LEDs signalizes the communication with the solar controller or VBCS Triple at the corresponding connection.

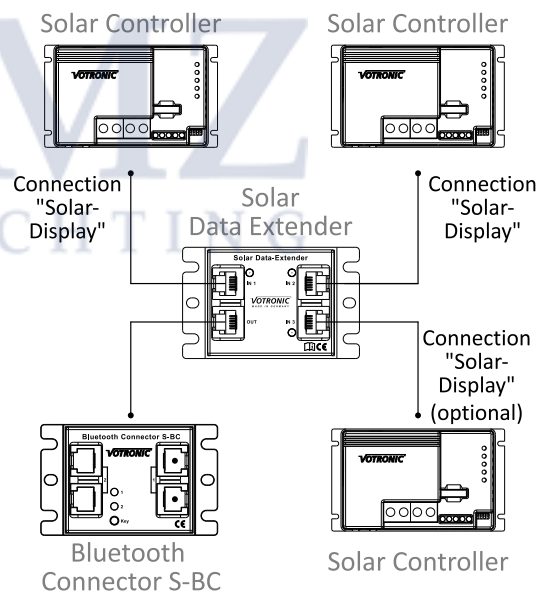



Safety Regulations and Appropriate Application:

The Solar Data Extender has been designed according to the valid safety regulations.

The Votronic Solar Data Extender aggregates the data of several solar controllers for representation on a single display.

Appropriate application is restricted to:

1. Technically faultless condition.
 2. Installation in a well-ventilated room, protected from rain, humidity, dust, aggressive battery gases, as well as in an environment being free from condensation water.
- Never use the unit in locations where the risk of gas or dust explosion exists!
 - Open-air operation of the unit is not allowed.
 - Cables are always to be laid in such a way that damage is excluded. Observe to fasten them tightly.
 - Never lay data cables and 230 V mains supply cables into the same cable conduit (empty conduit).
 - Check live cables or leads periodically for insulation faults, points of break or loosened connections. Occurring defects must be remedied immediately.
 - The unit is to be disconnected from any connection prior to execution of electrically welding or work on the electric system.
 - If the user is not able to draw from the manual, which characteristic values are valid for a unit or which regulations are to be observed, a specialist is to be consulted.
 - The user / buyer is responsible for the observation of construction and safety regulations of any kind.
 - Keep children away from the unit.
 - The unit is not equipped with parts, which can be replaced by the user.
 - Non-observance may result in injury or material damage.
 - The warranty period is 36 months from the purchase date (against presentation of the sales slip or invoice).
 - The warranty will be void in case of any inappropriate utilisation of the unit, if it is used beyond the technical specification, in case of improper operation or external intervention. We do not assume any liability for any damage resulting hereof. The liability exclusion is extended to any service being executed by third, which has not been ordered by us in writing. Service is to be effected exclusively by VOTRONIC D-36341 Lauterbach.

Trouble-shooting:

The display does not show any data:

- All solar controllers or the VBCS Triple are in stand-by mode and do not supply data.
- Check, if the Solar Data Extender is connected to the solar controller or VBCS Triple by observing the LEDs at the unit.
- Check the operating voltage (battery) of the solar controller at IN1.

Technical Data

Nominal Voltage (supply via the connected devices)	12 V / 24 V
Operating Voltage Range	8...32 V
Current Draw During Stand-by, Typically	0.7 mA
Current Draw During Activity (typically)	10 mA
Ambient Conditions, Humidity of Air	max. 95 % RH, no condensation
Dimensions	75 x 47 x 24 mm
Weight	approx. 37 g
Mark of Conformity	CE

Delivery Scope:

Solar Data Extender 3n1
3 Pcs. Control Cable 6-pins 0.5 m length

Available Accessories:

Extension Control Cable 5 m length Order No. 2005



Declaration of Conformity:

In accordance with the provisions of Directives 2014/35/EU, 2014/30/EU, 2009/19/EC, this product complies with the following standards or normative documents:
EN55014-1; EN55022 B; EN61000-6-1; EN61000-4-2; EN61000-4-3; EN61000-4-4;
EN62368-1; EN50498.



Disposal of the product in the household waste is not allowed.



The product conforms to RoHS. It complies with the directive 2015/863/EU for Reduction of Hazardous Substances in electrical and electronic equipment.

Quality Management System
DIN EN ISO 9001

Subject to misprints, errors and technical modification without notice.

All rights reserved, particularly the right of reproduction. Copyright © VOTRONIC 11/2020.

Made in Germany by

VOTRONIC Elektronik-Systeme GmbH, Johann-Friedrich-Diehm-Str. 10, 36341 Lauterbach/GERMANY

Phone: +49 (0)6641/91173-0, Fax: +49 (0)6641/91173-10, E-mail: info@votronic.de, Internet: www.votronic.de